

X-37 Storable Propulsion System Design and Operations

Henry Rodriguez

The Boeing Company, Huntington Beach, California, 92647-2099

Chris Popp

Marshall Space Flight Center (MSFC), Alabama, Huntsville, 35808

and

Ronald J. Rehagen

The Boeing Company, Florida Operations, Cape Canaveral, Florida, 32920

Abstract

In a response to NASA's X-37 TA-10 Cycle-1 contract, Boeing assessed nitrogen tetroxide (N₂O₄) and monomethyl hydrazine (MMH) Storable Propellant Propulsion Systems to select a low risk X-37 propulsion development approach. Space Shuttle lessons learned, planetary spacecraft, and Boeing Satellite HS-601 systems were reviewed to arrive at a low risk and reliable storable propulsion system. This paper describes the requirements, trade studies, design solutions, flight and ground operational issues which drove X-37 toward the selection of a storable propulsion system. The design of storable propulsion systems offers the leveraging of hardware experience that can accelerate progress toward critical design. It also involves the experience gained from launching systems using MMH and N₂O₄ propellants. Leveraging of previously flight-qualified hardware may offer economic benefits and may reduce risk in cost and schedule. This paper summarizes recommendations based on experience gained from Space Shuttle and similar propulsion systems utilizing MMH and N₂O₄ propellants. System design insights gained from flying storable propulsion are presented and addressed in the context of the design approach of the X-37 propulsion system.

introduction

The authors of this paper interviewed key designers and operators of multiple MMH/N₂O₄ propulsion systems, including: (1) the Space Shuttle Orbital Maneuvering System (OMS)/Reaction Control System (RCS), (2) the NASA/Jet Propulsion Laboratory (JPL) Cassini propulsion system, and (3) Boeing HS 601 satellites. The objective of this investigation was to identify known design concerns with storable systems so that the X-37 design might mitigate existing problems. Because of the wealth of experience gained from storable propulsion systems, a minimum risk approach was considered. The wealth of development hardware and design robustness provided the design approach to address the chronic issues related with storable propulsion systems.

Results and discussion

Requirements

Top Level Requirements that are defined for this vehicle are:

- Zero fault tolerance for on-orbit operations.
- Single-fault tolerance for safe-return.
- Accommodate 1000 lbf payload with maximum return payload of 1,000 lbf.

- The Vehicle shall be capable of an on-orbit mission of 270 days at an altitude of 150 nautical miles (nmi) with inclinations ranging from 28 to 57 degrees.
- The Vehicle System shall be capable of 10 orbital missions with refurbishment every 5th flight.
- Propellant load & drain in the vertical position. Provide 3-axis attitude control & 3 axis translation for on-orbit operations and 3-axis attitude control for ΔV and re-entry.
- Minimize propellant residuals prior to achieving entry interface.
- Comply with Eastern Western Range 127-1 requirements.

DERIVED REQUIREMENTS

The derivations of design requirements were driven by the Design Reference Missions (DRMs) and the Total Delta-Velocity requirements. From the DRMs and the specific Delta-Velocity events, burn times, pressurant and propellant mass consumption, and thruster cycles/pulses were derived. Orbital mechanics analyses and guidance and control analyses were performed to derive the specific engine life requirements for the X-37 OMS, Primary RCS (PRCS) and Vernier RCS (VRCS) (i.e. propellant throughput, burn duration, thrust pulses/cycles thermal cycles).

In the flight operations section of this paper, the specific DRMs are defined. In this section, the derivations of the specific system requirements are defined. Since the vehicle is designed for ten orbital missions, the types and number of missions had to be selected to define the total accumulated system life requirements. Since an early contingency return and DRM 5 are the worst-case propulsion missions. the following are the recommended missions for the assessment of system life requirements, with resultant derived thruster requirements as shown in Figure 1:

MDC Qty	Type of DRM	Flight #
7*	DRM 5	1,2,3,4 6,7,8
1	DRM 3	9
2	Early Contingency	5 & 10
* DRMs 2 & 4 are less severe than DRM 5. The requirements of DRM 5 encompass the requirements from 2 & 4.		

Figure 1 Thermal Cycles Analysis.

A thermal cycle is defined by the engine manufacturer to be the situation in which the engine accumulates sufficient heat to approach thermal equilibrium and then is allowed to cool down to a specific temperature such that thermal expansion and contraction stress the R512 silicide coating of the C-103 Columbian material (i.e. thruster chamber). Most bipropellant rocket engines that utilize MMH and N2O4 propellants feature a combustion chamber and exit nozzle made of a Columbian (Niobium) alloy C-103 coated with an R-512 silicide coating. The C-103 alloy's melting point is sufficient to withstand the hot combustion gases to temperatures exceeding 2500-3000°F; however, the alloy will rapidly oxidize at temperatures above 1200°F to 1400°F. Therefore, the silicide diffusion bonded coating enables operation at temperatures up to 2500°F by providing an oxidation protective coating for the C-103 material. Therefore, quantification of thermal equilibrium and cool-down periods are essential for each type of engine. For the OMS engine (OME), thermal cycles are assumed for every propulsive event because it is conservative that the engine will be allowed to achieve thermal equilibrium then cool

2500°F by providing an oxidation protective coating for the C-103 material. Therefore, quantification of thermal equilibrium and cool-down periods are essential for each type of engine. For the OMS engine (OME), thermal cycles are assumed for every propulsive event because it is conservative that the engine will be allowed to achieve thermal equilibrium then cool down. For the PRCS and VRCS type engines, it is difficult to ascertain a definition because the thermal characteristics of an embedded engine are not defined. Therefore, an estimate is determined by assessing the life-limiting concern. A thermal cycle for a pulse mode engine can be defined by the accumulated on-time where the engine is allowed to cool continuously (~30 to 60 minutes) within a specific duration (1 to 5 minutes activity). Since the PRCS is used mainly for re-entry, the thermal cycles were defined by the number of thermal cycles within the 15-minute duration per 120 seconds and the usage during an OME burn. This was determined by experience where the Shuttle thermal cycles are defined by 10% on-time within a 120 second period and where a 30 second period is allowed for no propulsive activity (i.e. cooled down). The number of thermal cycles can be estimated at approximately 8 to 30 thermal cycles for re-entry (15 minutes * 60 sec/min/120sec or 900 secs/30sec). An equal number of thermal cycles as the OME were added to address the propulsive activity during an OME burn. For the VRCS engines, the number of thermal cycles is preliminarily estimated based on types of maneuvers, as follows: 1 Thermal Cycle/week*4.5 weeks/month*9 months/mission = 41 thermal cycles (Refer to Figure 1).

Propellant Quantities

The propellant and pressurant quantities were defined based on using the rocket equation for a constant pure axial delta-velocity of 2300 ft/sec and Isp=313.5 seconds. Figure 2 shows the results of the tank sizing and the unusable allocations required to properly size the tanks. Although the propellant tanks are slightly different in volume, it is recommended that both tanks be equal at 17 ft³. The propellant mass is slightly different than the DRM analysis because the DRMs account for the degraded performance in pulse mode operations of the engines. It should also be noted that the DRM requirements involved significant long duration burns, which involve significant pressurant blowdown operations with resultant thermal and pressure level decreases.

Item Description	Units	Parameter	MMH	N2O4
Total Required DV	ft/sec	2,300		
Vehicle Final Wt	lbf	7,789		
OMS Residuals	lbm	175		
PRCS Entry Propellant	lbm	110	42	68
Helium Residuals	lbm	4		
Final Vehicle Wt at EI	lbm	7,500		
Avg Isp	sec	313.5		
gc	g/lbm ft/s	32.17		
Total Propellant Required	lbf	1,994.9	753	1,242
Mixture Ratio	o/f	1.648	795	1,310
Density @ 70 °F & 250 psia	lbm/ft ³		54.73	90.22
Total Propellant Volume Required	ft ³		14.52	14.52
MR uncertainties +/- 0.05 MR	ft ³		0.28	0.16
Unusable (unaccessible prop volume)	ft ³	2.0%	0.33	0.33
Ullage Volume	ft ³	5.0%	0.83	0.83
GSE Loading error	ft ³	1.0%	0.17	0.17
PVT Uncertainty	ft ³	3.5%	0.58	0.58
PMD & Tank internals	ft ³	2.0%	0.33	0.33
Total unusable	ft ³		2.52	2.40
	ft ³		16.79	16.79
Total Tank Volume Required	ft ³		17.04	16.93
Prop Vol + Ullage Vol. + Unusable Vol.	ft ³		17.04	16.93
Prop Vol + Ullage Vol. + Unusable Vol.	in ³		29,449	29,248
Unusable Propellant Remaining in the Tank				
RCS tax for OMS engine		6.75%	0.0	0.0
Tank residuals	lbm	1.0%	9.1	15.0
PMD residuals	lbm	1.0%	9.1	15.0
MR uncertainties +/- 0.05 MR, lbs	lbm	0.05	15.3	14.7
GSE loading weight error, lbs	lbm	1.0%	8.9	14.5
Tank residuals	lbm		42.3	59.2
PVT gauging error	lbm	3.5%	27.8	45.9
Zero PVT	lbm		70.1	105.0
Propellant Burned to Depletion	lbm		52.0	75.1
Residuals (lines)	lbm		0.8	1
Total unaccessible propellant, lbs			19	31
Total Loaded propellant, lbs			865	1415

Approved for public release; distribution is unlimited.

Figure 2 Consumable Quantities.

System Overview

To satisfy the requirements, the X-37 propulsion system is an MMH/N2O4 (Mon-3) system with OMS, PRCS, and VRCS capabilities. The system includes a pressurization subsystem, propellant storage tanks, a feed system, engines and various test port interfaces to enable tests and checkout for loading of consumables.

Figure 3 (OMS/RCS system schematic) presents the design layout of the propulsion system. Figure 4 (System Configuration) shows the notional propulsion system layout. The DRMs require an on-orbit mission duration of up to 9 months, orbit transfers between 150 to 250 nmi, and earth re-entry. Because of the previous lessons learned from propellant vapor transport associated with long-life applications, two separate pressurization subsystems (with associated mass and complexity impacts) were selected to prevent propellant vapor migration associated with one common pressurization tank; resultant mixture ratio variation due to pressurization level variations between the fuel and oxidizer systems can be accommodated by the existing capabilities for the selected thruster designs. Pressurant tanks require helium fill/vent couplings (MD 101/102). Pressurization panels have three couplings to allow checkout of high pressure isolation valves/regulators and to vent the propellant tanks while filling (MD105/MD 106).

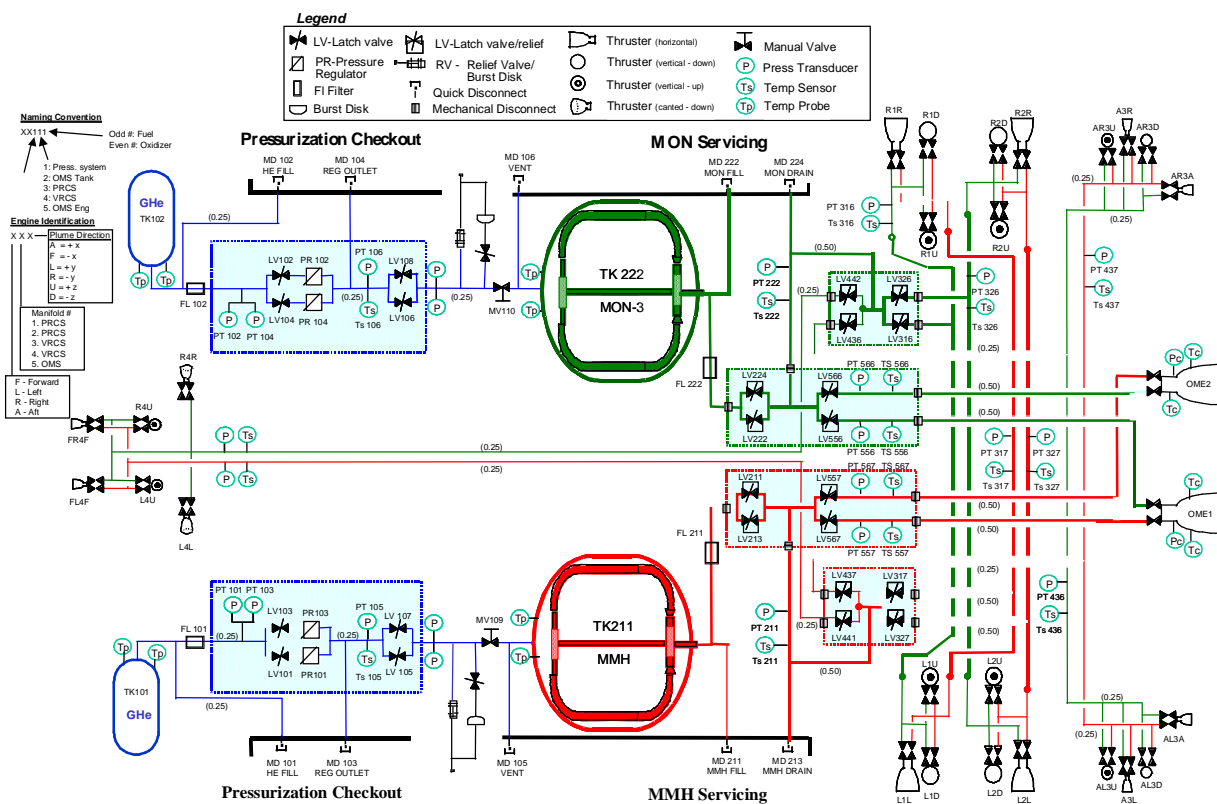

Figure 3 X-37 OMS/RCS Propulsion System.

The propellant storage tanks are protected against over-pressurization in the event of temperature rise or helium leakage. The system is configured for two-fault tolerance in high pressure isolation and is protected with a relief valve in the event of excess helium leakage or failed open regulator. The tanks are planned for a loading condition of 250 psig ullage pressure and 95% fill fraction. During on-orbit operation, propellant quantity gauging is accomplished using the pressure, volume, and temperature (PVT) method to assure sufficient propellant is available for vehicle return. Two pressure transducers and two temperature probes are proposed per Helium tank for quantifying Helium mass. Two pressure transducers and two temperature probes are proposed for propellant quantification. Propellant tanks require a vent (MD 105/106) and fill couplings (MD 211/222) to load and vent the tanks during propellant loading.

The feed system is designed to provide propellant distribution for orbital maneuvering and attitude control. Feed system valves are proposed with backpressure relief capability in the event of a locked or isolated line segment. The feed system is designed for maximum design pressure (MDP) criteria in each isolated line segment.

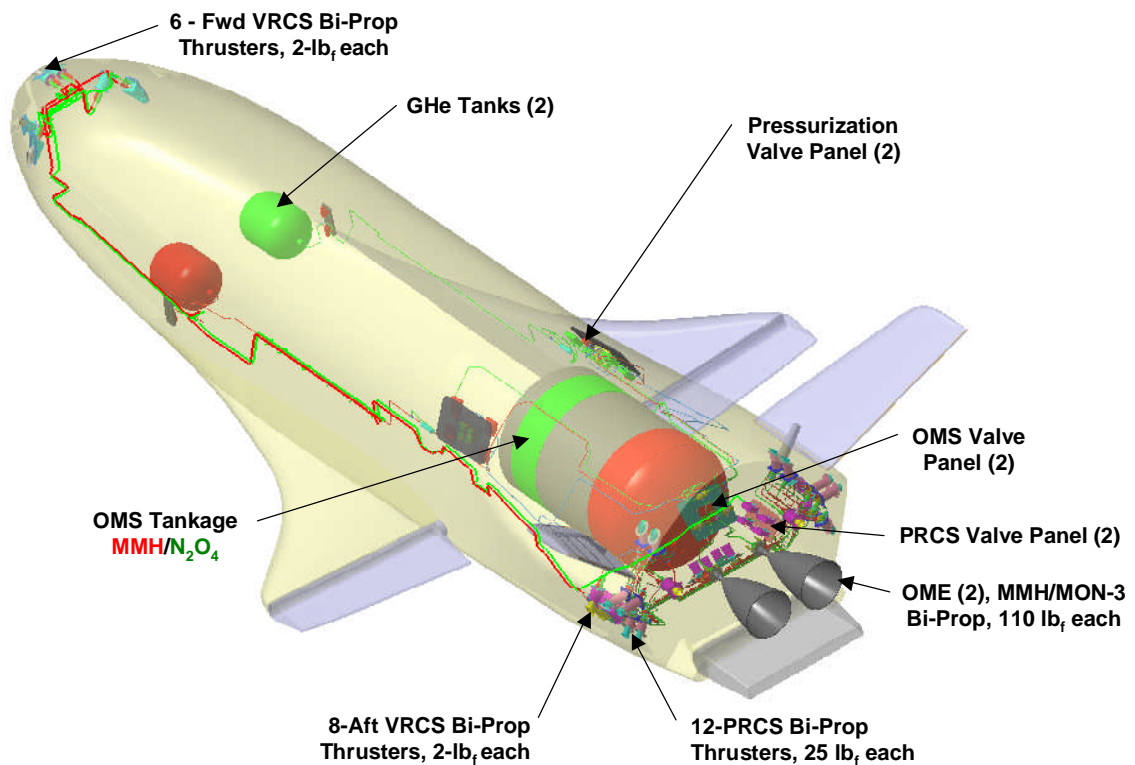

Figure 4 System Configuration.

The engine systems are designed with two 110-lbf thrust engines for orbital maneuvering, twelve 25-lbf thrust engines for primary attitude control and fourteen 2-lbf thrust engines for vernier attitude control. Engine thrust levels are based on existing engine designs which satisfy or partially satisfy propulsion system requirements and fulfill guidance, navigation and control mission requirements; however, throughput, thermal cycle, re-entry environment, and mission cycle life requirements will require some level of delta-qualification testing for some of the engines. During on-orbit quiescent modes, the concern of propellant leakage at the engine valve is ascertained by detecting temperature change at the chamber wall. Another design feature to quantify

propellant is to characterize valve pulses for gauging propellant (based on burn time integration) during dynamic operations. The data is then integrated to quantify propellant, which is essential to meet critical entry interface propellant residual requirements.

Trade Studies & Design Options

Various trade studies were performed to arrive at a feasible system configuration. System propellant, pressurization, and tankage trade studies were performed to select a low-risk propulsion system. A propellant system trade was performed that considered the following options:

- Option 1: Baseline all bipropellant subsystems (OMS, PRCS and VRCS)
- Option 2a: Bipropellant for OMS & PRCS and cold-gas for forward VRCS
- Option 2b: Bipropellant for OMS & PRCS and cold-gas system for entire VRCS
- Option 3a: Bipropellant for OMS & PRCS and Helium-pressurized monopropellant (Hydrazine) for VRCS
- Option 3b: Bipropellant for OMS & PRCS and GN2-pressurized monopropellant (Hydrazine) for VRCS.
- Option 4: All monopropellant OMS, PRCS and VRCS
- Option 5a: Dual Mode Engine Concept: Helium-pressurized bipropellant with Hydrazine & N2O4. OMS Bipropellant, Dual Mode: PRCS-bipropellant, Dual Mode & VRCS-Mono N2H4

Figure 5 shows an approximate 200 lbm mass decrease with a dual mode engine system and 144 lbm decrease for a cold gas/bipropellant relative to an all bipropellant system. As the result of investigating the relative cost difference, an all Bi-Propellant System is attractive because of the high cost of developing dual mode engine hardware. A cold system was not pursued because of its low specific impulse during fine attitude control, the potential for mission growth for this mission capability, and severe limitations in vehicle packaging of adequate cold gas storage capability.

Pressurization System Trade

Historically, long-life planetary exploration propulsion systems have not utilized regulators unless isolated with pyro-isolation valves during periods of inactivity, although recent NASA Discovery programs have used mechanical regulators with the potential for long duration exposure to propellant vapors. Commercial space propulsion systems do utilize mechanical regulators but typically operate in regulated mode for short durations (i.e. weeks) on-orbit prior to pressurization system isolation and subsequent blowdown mode operation; one case of a typical extended regulator operation did result in a significant regulator performance issue. Shuttle OMS/RCS pressurization systems do rely on mechanical regulator systems, but do have some history of regulator performance problems associated with propellant vapor exposure. Alternatively, there is limited flight system experience with pressure modulating systems, which involve more complexity (in system architecture, design and software/avionics integration).

There was no significant discriminator between a pressure regulator and pressure modulating (“bang-bang”) system. Five pressurization concepts were

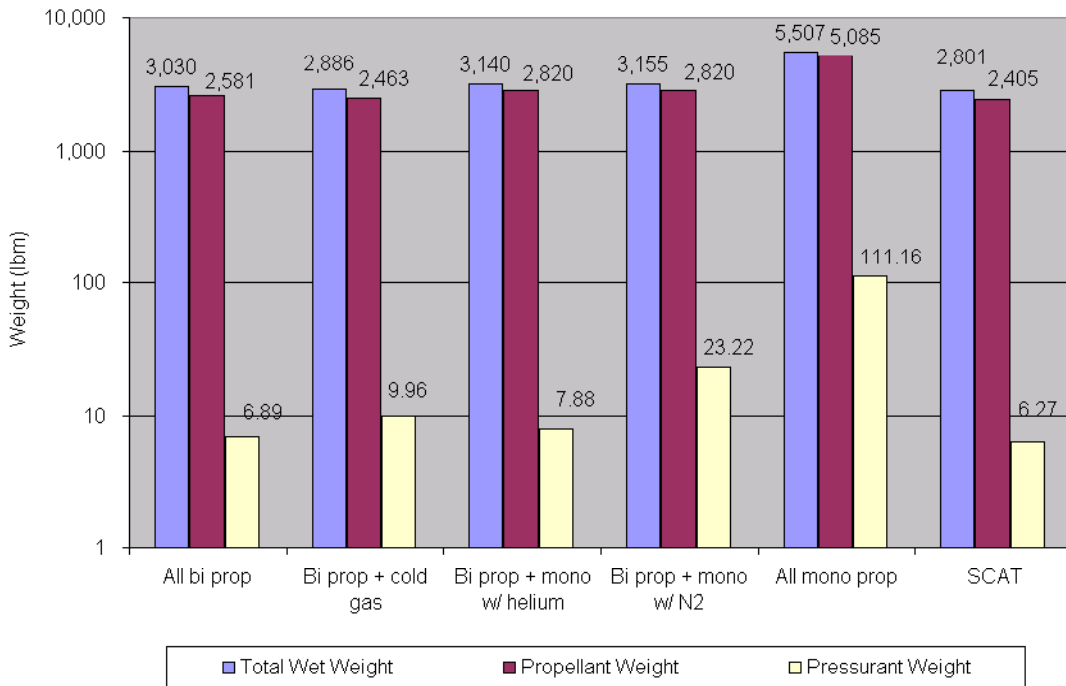

evaluated: (1) Pressure regulators, (2) bang-bang valves, (3) Quadruple regulators, (4) hybrid, and (5) hybrid with series regulators.

Figure 5 Propellant System Trade.

Algorithms were written to estimate the number of cycles that a pressure modulating system would be required to provide by the DRMs. For each mission, the OMS tanks were assumed to be 95% full at launch and 7% full at the end of mission. The 88% difference (i.e. 95% – 7%) in propellant fill levels equates to 2250 lbm. The ullage volume would increase from 5% to 93% due to usage of propellants. When the ullage volume expanded, the pressure was monitored and whenever the pressure went below 245 psia, the valve opened to allow helium flow until the ullage pressure increased to 255 psia. Each valve activation was counted as one cycle. To find out the maximum number of valve cycles, the ullage was assumed to be 100% helium. As a result, a regulator or valve was calculated to operate minimum of 73 times for a mission and 730 times (for 10 missions) for its life. Applying safety factor of 4, the total cycle life would be 4 x 730 = 2,920 times. Most valves or regulators are rated for least 10,000 cycles. Therefore, valve pulse count will not be a limited life issue.

Evaluation/Study Result					
Concept #	1	2	3	4	5
	Regulator	Bang-bang	Quad Regulator	Hybrid	Hybrid w/ 2 regs
Weight	2	3	1	3	1
# of parts	2	3	1	3	2
Software/Avionics Effort	3	1	3	1	1
Procurement Effort	3	3	2	1	1
Total points	10	10	7	8	5

Approved for public release; distribution is unlimited.

Figure 6 Results of Pressurization System.

The regulator and bang-bang concepts were compared and found to be competitive relative to the other three system configurations. The bang-bang concept may weigh less because of the elimination of regulators but it requires more software and avionics integration (i.e. higher cost).

The proposed configuration of pressure regulators was selected because of the simplicity of mechanically self-controlling tank pressure, without the need for additional software/avionics hardware, and due to cost (refers to Figure 6). Another strong reason for selecting mechanical regulators with separate pressurization systems was the historical precedence and flight performance of the Shuttle OMS/RCS, which utilize mechanical regulators. Finally, the regulator concept was chosen due to the capability to terminate long duration X-37 missions early and return to ground for refurbishment should a regulation failure occur, as well as the future/contingency growth capability to utilize pressurization isolation valves as pressure modulating valves under regulator failure conditions.

Pressurization System Issues

A survey of pressurization systems was conducted by investigating the Space Shuttle OMS/RCS, Boeing Satellite HS 601 and NASA/JPL Cassini propulsion systems. This assessment was conducted to address the long-term exposure issues with pressurization systems

For the Shuttle OMS/RCS, propellant vapor migration has affected regulators because the inability of the check valves to prevent propellant vapor transport. The purpose of the check valves is to prevent propellant (liquid and vapor) from migrating upstream and affecting the regulators. With over 100 flights of experience, it has been shown that propellant contaminants and residuals known as nitrates have bypassed the check valves and caused multiple anomalies. It has been observed that the RCS systems which have a mechanical pressure regulation system exhibit many anomalies because of the long term exposure to propellant vapor--specifically on the N2O4 side. On the OMS systems, the pressurization system exhibits fewer anomalies than the RCS because of vapor isolation valves which mitigate the N2O4 high vapor pressure. The MMH vapor migration concern is not significant because of the low vapor pressure on the MMH side.

The OMS system does have check valves; however, on the oxidizer side, propellant vapor isolation valves are positioned to prevent propellant vapor transport. It has been observed that a significant reduction of anomalies occurs because of the isolation barrier of the vapor valves. Because of this experience, it was highly recommended to architect the X-37 pressurization system with vapor isolation valves to minimize the propellant vapor transport concern.

For the HS 601 satellite propulsion system, the pressurization system issues are limited because the architecture is fixed in blow-down mode after the long liquid apogee motor (LAM) burn. After a period of two week on-orbit, a pyro-isolation valve is closed,

isolating the regulator from propellant vapor, so there is limited insight to address propellant vapor transport.

For the NASA/JPL Cassini propulsion system, multiple pressurization legs are configured with pyro-isolation valves to prevent propellant vapor transport and to assure propellant contaminants do not impact regulator performance. A pressurization system is also constantly tested to study the effects of long term exposure. It was concluded from investigating the above three system architectures that regulators require an isolation barrier to protect against propellant vapor transport. The separate pressurization systems with vapor isolation valves were selected to prevent a catastrophic event from two hypergolic vapors and to architect a pressurization system to provide quantity gauging without the complexity of helium mass accounting.

Tank Trade

A tank configuration trade was conducted under the following assumptions:

- Tank concepts must provide on-orbit & re-entry liquid acquisition.
- Tank envelope is 39.15" I.D. x 65.56" long for 4-tank system.
- Tank envelope is 39.15" I.D. x 68.56" long for a 2-tank system.
- Specific impulse vs. mixture ratio curves were fixed based on existing engines.
- Vehicle re-entry mass: 7500 lbm
- Non-propulsive consumables: 300 lbm
- Tanks with cylindrical sections were considered Load-bearing
- Spherical & ellipsoidal tanks were considered non-load-bearing.
- Mounting method: Skirt-based

Layout configurations as shown in Figure 7 were evaluated in the trade study.

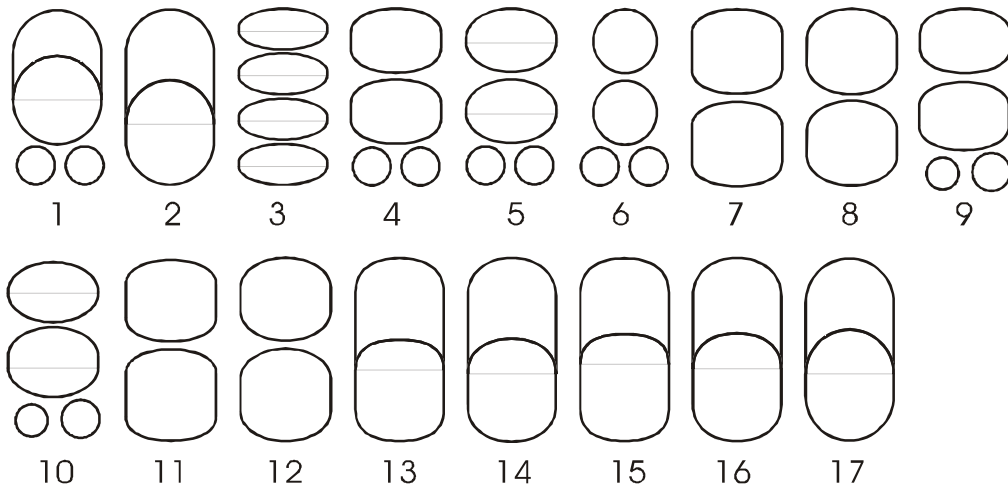

Figure 7 Propellant Tank Configurations.

Once the basic requirements listed above are satisfied, the best configuration is to select a tankage system that has quick turnaround capability and has low development effort. Selecting a tankage system with low turnaround features minimizes unnecessary tanks interfaces for propellant draining. Operability was considered the highest weighting criteria because of the labor required for the Space Shuttle Program, which has proven to be time driven. It has been experienced on the Orbiter Program that multiple interfaces, such as test port access, add to the entire turnaround operations. A tank should be designed to minimize tank draining or venting to minimize ground operations.

The performance for concept 7 provided moderate delta-velocity improvement compared to the other concepts considered; however, the best development approach was an option which requires fewer tanks because tooling, manufacturing processes and learning curves are significantly reduced. A development approach with design heritage offers a lower development cost because of the tooling and assembly learning curves are known. Concept 7 has identical fuel & oxidizer tanks and thus reduces the development effort.

A clear recommendation can be made for heritage propellant storage tankage. A two-tank design will have lighter plumbing and lower valve masses than a four-tank system, but carries implications for the propellant residuals because of gauging uncertainties with larger volumes.

Development risk is similar to a qualitative cost metric; however, a parametric cost analysis is required to determine magnitude of cost differences and was outside of the scope of this trade study. Concept 7 is recommended above all others due to its excellent operability, moderate delta-velocity performance, and low development risk.

Flight Operations

The system design is significantly impacted by the DRMs and the flight operations needed to accomplish them. DRMs were used to assess the propellant consumption profiles by calculating the ΔV required to perform orbit transfers or the impulse required to perform PRCS and VRCS propulsion functions. The amount of propellant required by each propulsion function drives the type of propellant management device (PMD) design and drives the type of feed system needed to distribute propellant. The intent of this assessment was to define the flight operations, estimate the system duty cycles and to define engine life requirements to execute procurement.

A description of the DRMs is provided in Figure 8. DRMs were assessed to estimate the total ΔV required to perform the various missions. All operations are considered to assure the PMD acquires the required propellant for all functions.

- DRM 1 is a ground taxi mission and requires no propulsive ΔV .
- DRMs 2, 4, and 5 are essentially the same in terms of orbital altitude of 150 nautical miles (nmi) with a +/- 10 nmi tolerance and with the exception of on-orbit duration of 3, 270, and 270 days, respectively, and orbital inclinations of

39o, 28.5o, and 57o, respectively.

- DRM 3 is defined as an Orbital Space Plane (OSP) mission where the mission begins at 150 nautical miles and performs its major mission functions at 250 nmi with a +/- 10 nmi tolerance. With the exception of DRMs 1 & 4, all DRMs require returning the vehicle at a final re-entry weight limit, including payload, of 7,500 lbs (DRM 4 requires a vehicle re-entry weight limit of 6,500 lbs)

DRM#	Description	Orbit Insertion	Altitude	Orbit Duration	Return Orbit	Inclination
DRM- 1	Taxi	None	None	None	None	None
DRM- 2	Checkout Mission	150 nmi circular	150 nmi circular	3 days	150 nmi circular	39°
DRM- 3	OSP Demo	150 nmi circular	250 nmi circular	7days	150 nmi circular	51.7°
DRM- 4	Nominal Long Duration Min Inclination	150 nmi circular	150 nmi circular	270 days	150 nmi circular	28°
DRM- 5	Nominal Long Duration Max Inclination	150 nmi circular	150 nmi circular	270 days </tr		

● Denotes Engine Burn

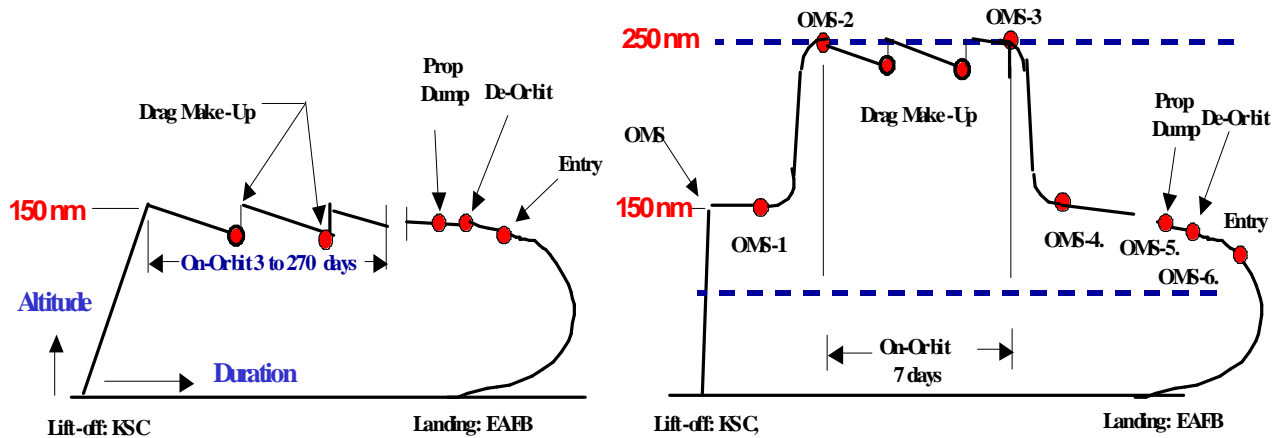

Figure 8 X-37 Design Reference Missions.

Because the maximum re-entry mass limit is defined as 7,500 lbs which includes a 500 lbs payload (and 500 lbs vehicle reserve margin), re-entry propellant, propellant residuals and other consumables for other subsystems (such as NH3 for TCS), the propulsion consumable analyses revealed the amount of propellant depletion required to meet the re-entry mass target of 7,500 lbs. By maximizing the propellant volume within the geometric constraints, the maximum usable propellant of 2,131 lbs was greater than the maximum propellant required for each DRM. This introduced a derived flight operation requirement to deplete propellant in order to meet the re-entry mass limit of 7,500 lbs. The required depleted propellant to meet the re-entry mass limit of 7,500 lbs for each DRM is 1,777 lbs, 1,118 lbs, 1,065lbs and 985 lbs for DRM 2, 3, 4 and 5, respectively.

The results of the consumable analysis revealed that the total propellant capacity of the propellant tank can be consumed within the mission times. Propellant consumption analysis for DRMs 2, 3, 4, 5 and contingency early return (Figure 9) defined the system total impulse and engine requirements. The most severe mission is defined by an early contingency return case where propellant depletion is required within a 2

hour period. From the standpoint of a propulsion system capability, the system can be designed to support the feasibility of depleting propellant within a 90 minute period.

The propellant consumption analysis defined the mission timelines, flight operation requirements and the propellant required by OMS, PRCS and VRCS. This analysis revealed that propellant depletion can take 90 to 43 minutes depending on the number OMS engines used. Two OMEs plus 6 PRCS were assessed to determine the depletion time of 28 minutes. The current baseline can support two OMEs during a depletion burn. During a normal mission (DRMs 2, 3, 4 or 5), the propellant depletion can range from 900 lbs to 1200 lbs of propellant (approximately 1 hr).

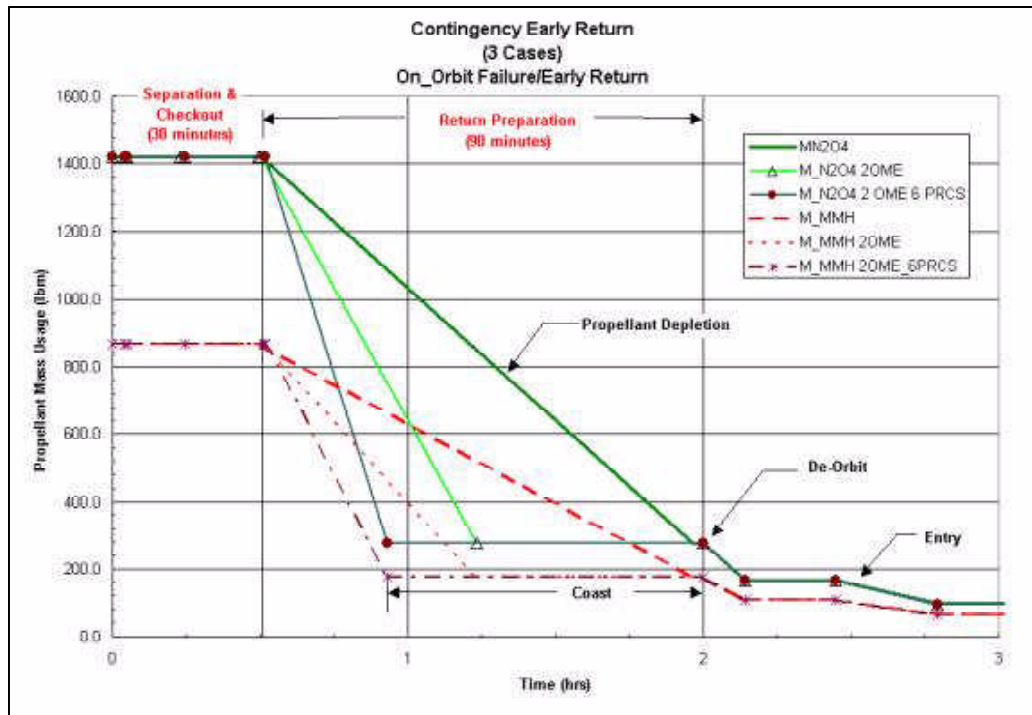

Figure 9 Contingency Early Return.

For the return from orbit event, the OME de-orbit burn is accomplished at 150 nmi utilizing 194.39 lbm of propellant for an OME burn and 1.22 lbm for PRCS thrust vector control (TVC). During the next 17 to 18 minutes, the PRCS is required to provide coast control to entry interface. The de-orbit burn will be accomplished after the required propellant depletion burn(s). Guidance navigation and control (GN&C) analysis provided de-orbit propellant estimates. The OME burn was estimated at a burn time of 554 seconds (9.2 minutes). During the 554 seconds OME burn, PRCS propulsive activity is provided to maintain the vehicle within a specific thrust vector. The total PRCS (L1U, L1L, L1D, R1U, R1R, R1D) on time is estimated to 1 second due to precise OME thrust axis orientation control through the vehicle center-of-gravity.

After OME shutdown (17 to 18 minutes), PRCS propulsive activity is provided to control the vehicle down to the entry interface. The total PRCS usage was estimated to comprise 11.7 seconds of on-time. Thruster pulse widths range from 0.020 seconds to

0.160 seconds. Although the current requirement for the PRCS minimum electrical pulse width (EPW) was specified at 0.040 seconds, the authors of the paper do not view the lower EPW as a feasibility concern because the TVC (2% duty cycle, 12.68/554) duty cycle required is extremely low (i.e. 2% on time of the OME burn) for the full 27 minute duration (refer to Figure 10).

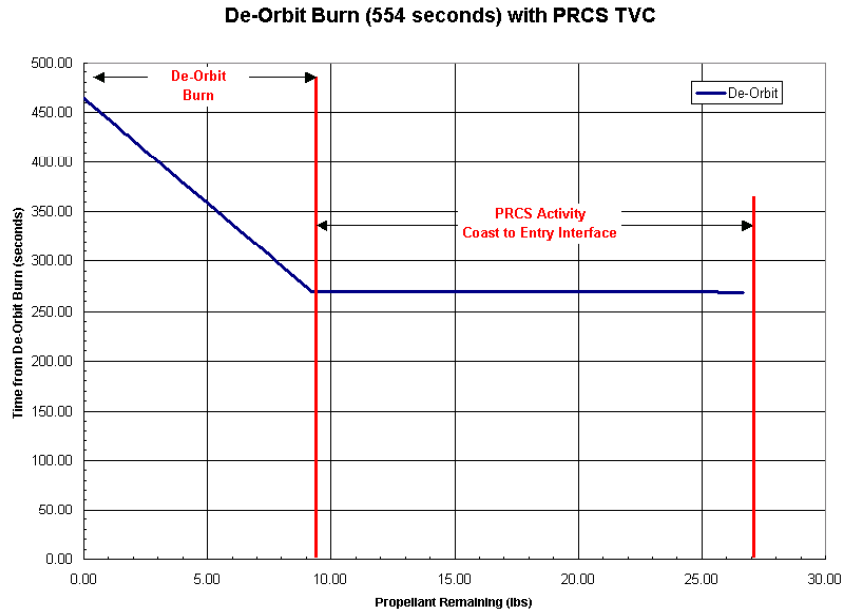

Figure 10 De-Orbit Burn with PRCS TVC.

The propulsion system provides propulsive activity during the re-entry phase of the mission down to an approximate altitude of 90,000 ft (Mach No=2.5). The re-entry phase of the mission down to weight-on-wheels (WOW, i.e. landing) is approximately a 30 minute duration. The propulsive activity starts at the completion of de-orbit burn and ends at Mach No. = 2.5.

The PRCS can utilize up to 110 lbm of propellant (42 lbm-MMH & 68 lbm-N2O4) during the re-entry phase of the mission depending on the type of inclination and dispersions (refer to Figure 11). The propellant consumption is relatively minor relative to the last two minutes of a 15-minute re-entry activity. The propellant consumption was estimated using a GN&C model. The model considers the vehicle geometry mass properties, atmospheric air density, drag, and torque disturbances during the re-entry phase. The model tracks engine pulses, pulse widths and total propellant consumption per engine. It was assumed that manifold 1 of the PRCS is the primary system and manifold 2 of the PRCS is the redundant system. The model predicts PRCS engines R1D, L1U and L1U as the most stressed engines during the re-entry phase.

The analysis defines the system and engine duty cycles needed for evaluation of

heritage hardware for the X-37 application. The proposed Aerojet R4D engine (OME application) has been tested to 44,000 seconds and the Shuttle-heritage Aerojet R1E (PRCS application) has been tested to over 100,000 seconds of on time. The analysis shows that the OME requirement is defined between 4,500 to 5,500 seconds per mission (55,000 seconds for 10 missions). The PRCS engine on time can range from 2,800 seconds to 3,000 seconds per mission (30,000 seconds for 10 missions). The VRCS engine on time is defined as 21,600 seconds per mission (216,000 seconds for 10 missions). For the VRCS, data from a delta-qualification test report showed that two engines (2 lbf) have demonstrated 151,362 seconds and 99,354 seconds of total on-time which is 4 to 5 times the single mission on-time VRCS requirement.

From these comparisons, it can be stated that feasibility concerns can be overcome for the R4D, R1E and the VRCS type engines by delta-qualification and some redesign packaging for structural mounting. Thermal conditions associated with on-orbit solar and re-entry heating will have to be addressed to assure design compliance. If the vehicle maintains the proposed flight rate, replacement of engines can be a feasible option to meeting all engine requirements. The duty cycles defined for the OME, PRCS and VRCS engines can be performed with heritage engines requiring delta-qualifications and structural redesign. The analysis presents an acceptable feasible assessment of the engine requirements compared with available heritage type engines.

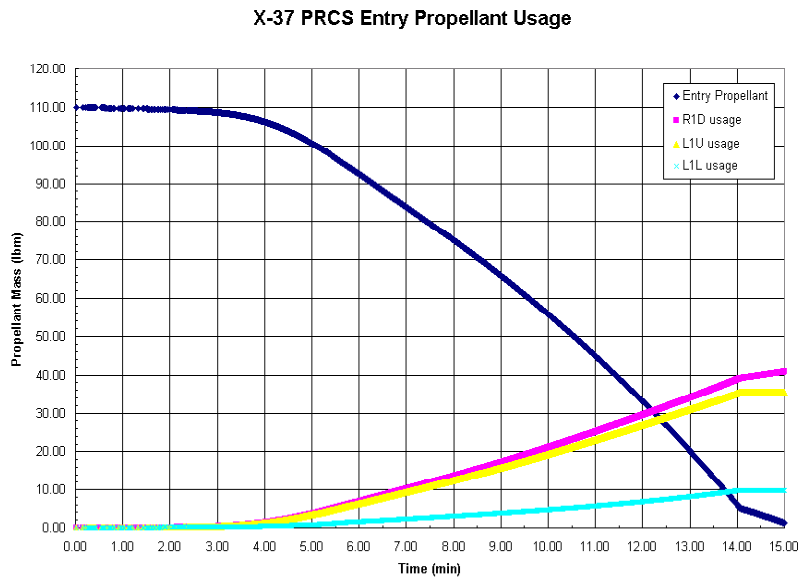

Figure 11 PRCS Entry Propellant Usage.

After re-entry, venting is required to reduce the ullage pressure build-up in propellant tanks during descent. The tank pressure will increase rapidly due to re-entry heating soak-back. In order to avoid the 280 psia maximum expected operating pressure (MEOP), avoid venting on the ground (personnel safety issue), and provide one failure tolerance protection of the design MEOP, it is necessary to actively vent the ullage pressure from the tanks. An analysis was performed to determine the optimal venting scheme (when to vent and how long) for both N2O4 and MMH tanks (Figure 12); only the N2O4 side is shown because it has the higher vapor pressure. Continuous venting is the preferred method, since pulse purge venting would impose more cycles on valves

and takes longer to achieve the same pressure level. Venting in the atmosphere is preferred since it is less hazardous for ground crew and also requires less time to vent tanks due to lower temperature compared to venting on the ground

Ground Operations

Experience from the Shuttle program has shown that ground operations contribute a large share to the life cycle cost of the flight program. Utilizing existing facilities, ground support equipment, test and loading techniques can minimize the cost of launch and post-landing ground operations; similarly, configuration of line replaceable units in modular valve panels for checkout/refurbishment accessibility, as done for the X-37 design, can improve checkout and reduce cost. The identification of the Kennedy Space Center (KSC), Cape Canaveral Air Force Station (CCAFS) and offsite local assets for utilization in X-37 ground processing is mandatory in the formulation of efficient, safe, and feasible ground processing concepts.

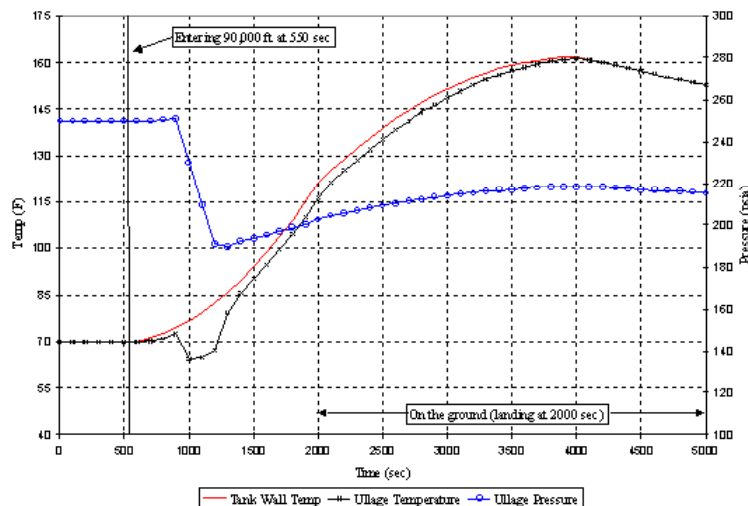

Figure 12 Re-Entry Venting.

An assessment was made to determine the feasibility of design relative to ground turnaround processing, propellant/pressurant loading, and pre-flight/launch countdown activities. Through this assessment and the consideration of ground operational issues, the design development of the propulsion system considered compatibility with existing KSC/CCAFS hypergolic infrastructure, and has the potential to minimize problematic and chronic issues that have plagued previous ground processing such as experienced by Shuttle OMS/RCS processing.

The relative small size of the X-37 propulsion system, as compared to the Shuttle OMS/RCS systems, lends itself to be processed and loaded utilizing satellite processing and loading facilities and equipment. The extensive experience gained from processing the Shuttle OMS/RCS hypergolic systems coupled with the procedures and experience of handling/loading satellites with hypergolic propulsion systems is proposed for the X-37 to alleviate concerns ranging from loading/activation to range safety

concerns while attached to the expendable launch vehicle at the launch pad.

For pre-flight functional tests, the propellant system components will require testing prior to flight to verify the integrity of the system. The level of testing is dependent upon the point at which the vehicle is along its flight schedule path. The functional tests are divided into two categories...1) first flight functional tests, and 2) post-flight turnaround functional tests.

For the first flight functional tests, upon arrival of the X-37 vehicle at KSC, the propulsion system will require a full checkout to verify the integrity of the system was not compromised during transport operations. This serves two primary purposes: 1) verify integrity of the system prior to flight to assure mission success, and 2) verify integrity prior to introducing hypergolic propellants to the system. It is highly desirable to detect a failure of a system component prior to introducing propellant to the system, since the subsequent repair of that component would be non-hazardous with minimal impact to operational schedules. Additionally, full checkout creates a baseline of data at the launch site to compare to subsequent turnaround testing results. Based on Shuttle experience, vendor test data versus launch site test data may have subtle differences due to differences in the ground support equipment and testing methods.

Functional tests and internal leak checks of all components of the system are recommended, and to an extent required by Range Safety requirements. The following is a list of the type of tests to be performed on specific components:

- Solenoid valves - cycled for proper function followed by internal leak checks to verify in-specification conditions.
- Engine valves – timing tests, forward and reverse leakage tests
- Relief valves – crack and reseal tests
- Burst discs – leakage tests
- Regulators – flow response tests, leakage tests

Three-point calibrations of all critical pressure transducers are recommended. This ensures each measurement is providing accurate data, which is critical for quantity gauging activities and entry mass margin requirements. All pressure transducers will be tested one time prior to first flight to set a performance baseline. Critical measurements are then retested periodically to check for drift.

External leak checks of all mechanical and welded joints, components, flex hoses, and quick disconnects (QD's) are recommended for test prior to propellant loading. A mass spectrometer will be used to detect any helium gas leakage emanating from the joint or component. Heater and electrical tests are recommended which include channel identification and line heater circuit verification.

Propellant loading is an extremely hazardous operation and is a major impact to facility operations, requiring facility clears of all nonessential personnel. Additionally, the operation requires essential personnel be attired in Self-Contained Atmospheric Protective Ensemble (SCAPE), and fire and medical personnel on standby. Evaluation of the KSC/CCAFS and offsite facilities was conducted to determine the feasibility of

loading the X-37. The sites considered have the infrastructure to support highly toxic, highly hazardous, hypergolic propellant loading. The infrastructure required includes the following:

- Fill/drain/vent systems
- Toxic Vapor Scrubbers
- Facility interfaces for connection of loading GSE
- Aspirators
- Hypergolic exhaust fans
- Storage tanks, pumps, and thermal conditioning units or the ability to allow connection of this equipment.
- Helium & GN2 supply panels

Preliminary findings focused the loading of the X-37 propulsion system at the offsite facility, Astrotech in Titusville, Florida, which is more than capable of handling the X-37 vehicle and subsequent hypergolic loading operations. Preliminary plans call for existing loading equipment utilized for loading propellant onto satellites to be used for the X-37. This equipment will be required to be transported to the Astrotech facility for connection and utilization for X-37 loading.

After the X-37 vehicle arrives at the launch pad and is mated to the expendable launch vehicle, the helium system will be activated for flight and the tanks pressurized to flight mass. This will require the connection of two helium supply quick disconnects (QD's) to the vehicle. Once the system has been activated, pressurized for flight, and verified to be stable, the QD's will be demated and the vehicle panel secured for flight. The following is the overview for helium system activation and pressurized for flight:

- Open propellant tank isolation valves, and verify the pressure and temperatures are stable.
- Activate the helium system for each commodity (NTO and MMH)
 - o Pressurize helium tanks to 700-800 psia to allow for a mini-slam of the regulators (Aids in reducing leakage through regulators and minimizes potential for large pressure spikes in the propellant tank ullage)
 - o Open vapor isolation valves and verify propellant tank pressure does not exceed 140 psia
 - o Open helium isolation valves (A then B; to allow verification that propellant tank ullage pressure is not more than regulator lockup pressure and that propellant system pressure is stable at flight pressure)
- Pressurize helium tanks to flight pressure and verify system is stable
- Disconnect GSE QD's from vehicle and closeout flight panels (install flight caps, doors, etc.).

The propulsion system will be in a stable mode during terminal launch countdown. With the exception of activation of the heaters for flight, the propulsion

system is ready for flight. Console operators will be required to only monitor system pressures and temperatures.

In the event of propellant system leakage while the vehicle is at the launch pad, emergency securing would need to be performed. Extensive experience in this area and existing KSC/CCAFS procedures will be employed to control the emergency situation. The following is an overview of the actions that would be necessary to control an emergency situation:

- Close propellant tank isolation valves
- Close associated manifold valves
 - o Monitor pressure/temperatures for stable readings
- Close helium tank isolation valves and vapor isolation valves
- Assess further safing and clean-up measures
 - o Propellant/pressurant offload GSE to be staged for use
 - o Severity of leakage will dictate the course of action and impact the following
 - o Utilize existing site procedures for hypergolic spill/leak recovery

Summary and conclusions

A hypergolic propulsion system for X-37 was designed to minimize design and development cost and risk and to reduce ground processing by utilizing the lessons learned from Space Shuttle, HS 601 satellite, and Cassini. This paper presents the current development efforts accomplished during the TA-10 Cycle-1 contract, which required a two-year development effort. A storable system with MMH and N₂O₄ propellants was selected because of the immediate request to provide a design at low risk and cost and with significant delta velocity capability. Significant heritage hardware can be modified with a delta-qualification to address the thermal, vibration and life requirements. Key to the design is the applied lessons learned from Shuttle and other NASA long-term spacecrafts. This design offers a low risk system because the safety and hazards and performance issues learned from other toxic systems are addressed. During the course of the development effort, the significant issue of venting, due to the heat flux exhibited during earth re-entry, was presented. To resolve the problem, the system design incorporated active and passive vent systems to both provide venting operations for normal operations and to provide a fail-safe system. In summary, the X-37 propulsion was developed to be a robust system that addresses the safety hazards, but minimizes development, cost and risk.

The X-37 propulsion system design has taken the lessons learned from previous flight systems and available heritage hardware into consideration to apply the driving requirements and arrive at a low risk and low cost system within the development timelines.

This system has also been designed to be compatible with existing KSC/CCAFS hypergolic infrastructure and Range Safety requirements. During the design phase of the X-37's propulsion system, the consideration of the wealth of experience gained and lessons learned in ground processing of the Shuttle's OMS/RCS system and payload hypergolic propulsion systems resulted in a design that is feasible relative to ground turnaround processing. The goal was to design a system utilizing existing hardware and experience gained to minimize cost. Additionally, in utilizing these lessons learned, the X-37's propulsion system design has the potential to

minimize problematic and chronic issues that have plagued Shuttle OMS/RCS and other processing.

acknowledgments

The authors would like to thank the NASA JPL (Carl Guernsey), MSFC (Pat McRight & Bob Sackheim), Kennedy Space Center agencies and Boeing Florida Operations (Ron Rehagen and Connie Perez) for their extensive experience in accumulated information from Space Shuttle, JPL long term Space Vehicles and MSFC Propulsion Systems.

references

1. Boeing Reusable Space System, ***Non-Toxic System Architecture for Space Shuttle Applications***, AIAA-98-3821, July 12-15, 1998.
2. Boeing Reusable Space System, ***Non-Toxic Cryogenic Storage for OMS/RCS Shuttle Upgrade***, AIAA-98-3821, July 12-15, 1998.
3. Boeing Internal Study/Henry Rodriguez, ***Boeing Supportability and Obsolescence Study***, 2001.
4. Boeing Reusable Space Systems, ***Main Propulsion System Maintainability Issues for the Future Shuttle***, AIAA-02-3756, July 7-10, 2002.